

# Journal of Economics and Business

**Salim, M. Noor, and Winanto, Hardian Arief. (2020), Determinant Return on Assets and Its Impact on Assets Growth (Case Study of Sharia General Banks in Indonesia). In: *Journal of Economics and Business*, Vol.3, No.1, 282-294.**

ISSN 2615-3726

DOI: 10.31014/aior.1992.03.01.197

The online version of this article can be found at:  
<https://www.asianinstituteofresearch.org/>

Published by:  
The Asian Institute of Research

The *Journal of Economics and Business* is an Open Access publication. It may be read, copied, and distributed free of charge according to the conditions of the Creative Commons Attribution 4.0 International license.

The Asian Institute of Research *Journal of Economics and Business* is a peer-reviewed International Journal. The journal covers scholarly articles in the fields of Economics and Business, which includes, but not limited to, Business Economics (Micro and Macro), Finance, Management, Marketing, Business Law, Entrepreneurship, Behavioral and Health Economics, Government Taxation and Regulations, Financial Markets, International Economics, Investment, and Economic Development. As the journal is Open Access, it ensures high visibility and the increase of citations for all research articles published. The *Journal of Economics and Business* aims to facilitate scholarly work on recent theoretical and practical aspects of Economics and Business.



ASIAN INSTITUTE OF RESEARCH  
Connecting Scholars Worldwide



# Determinant Return on Assets and Its Impact on Assets Growth (Case Study of Sharia General Banks in Indonesia)

M. Noor Salim<sup>1</sup>, Hardian Arief Winanto<sup>2</sup>

<sup>1</sup>1975801189@mercubuana.ac.id, m\_noorsalim@yahoo.com, Mercubuana University, Jakarta Indonesia

<sup>2</sup>hardian\_arief@ptpjb.com, hardian\_arief@yahoo.com, PT Pembangunan Jawa Bali, Surabaya Indonesia

## Abstract

This study aims to examine and analyze the determinants that influence Return on Assets (ROA) and their impact on Asset Growth (AG) partially or simultaneously. Factors affecting ROA and also Asset Growth are specific to Human Capital efficiency (HCE), Structure Capital efficiency (SCE) Capital Employed Efficiency (CEE), Board of Education (BED), and Board of Evaluation (BEV) on Return On Assets (ROA) and Asset Growth (AG). The population of this study is Sharia commercial bank companies in Indonesia with an observation period from 2014 to 2018 consisting of a sample of 12 Sharia Commercial Bank companies. The data analysis techniques in this study used Multiple Linear Regression analysis by analyzing the effect of corporate governance and Intellectual Capital to the Return On Asset and Asset Growth of the corporate partially and simultaneously. The results of data analysis showed that ROA was partially influenced by a significant positive of HCE and AG was significantly positive by ROA. While simultaneously, all variables significantly influence positively on ROA and Asset Growth.

**Keywords:** Human Capital Efficiency (HCE), Structure Capital efficiency (SCE), Capital Employed Efficiency (CEE), Board of Education (BED), Board of Evaluation (BEV), Return On Assets (ROA), Asset Growth (AG)

## 1. Introducing

This research was conducted because it saw a growing phenomenon in the country of Indonesia that the development of Islamic banks has increased since the last few years. The development of Islamic banks shows that public awareness of religion is increasingly high. The development of Islamic banks is not only determined by the amount of capital invested, but also to the readiness of employees of Islamic commercial banks in applying the principles of Islamic banking in accordance with Islamic teachings.

Slowly, Islamic commercial banks are able to meet the needs of the public who want banking services in accordance with sharia principles, particularly those relating to the prohibition of usury practices, non-productive speculative activities and violations of the principle of fairness in transactions and the necessity of channeling financing and investment in business activities which is ethically and halal in sharia. (Zubair, 2008).

Since the establishment of the first Islamic bank, another sharia bank began to emerge, which as of December 2018 there were 14 Islamic commercial banks in Indonesia with an average total asset of 298,044 billion rupiahs. (www.ojk.go.id).

Previous research has concluded that intellectual capital can be used to improve corporate financial performance, while corporate governance cannot be proven to be used to improve financial performance. (Ningrum, et al. 2012). That study was conducted on 54 financial companies listed on the Indonesian stock exchange.

In addition, Kurniasih, et.al (2016) concluded that if the company is able to manage the intellectual capital that they have better, the higher Return on Assets (ROA) can be made by the company.

Also research by Nuswandari (2009) focuses on the influence of corporate governance on company performance. The study was conducted on 101 companies listed on the Indonesia Stock Exchange with the period 2001 to 2005. In this study, it was concluded that the implementation of good corporate governance and in accordance with applicable regulations will make investors respond positively to the company's performance and increase the company's market value. (Nuswandari, 2009). In summary, it can be said that corporate governance affects the company's operating performance.

Tertius (2015), concludes that the board of commissioners, independent commissioners, and managerial ownership as joint control variables have a significant effect on the dependent variable that is ROA.

Meanwhile, previous research on asset growth in Islamic banks has been conducted by giving the results that the internal variables that significantly influence the growth of Islamic banking assets are only the number of offices, FDR ratio, and promotion costs, while for other internal variables, namely the NPF ratio and the amount of funds third parties do not significantly influence. (Syafrida, et al. 2011).

Based on the phenomena and previous studies, there is a research gap that the writer gets and is taken as a research theme. The author takes research by taking samples of Islamic commercial banks in terms of the application of corporate governance and intellectual capital, its implications for the company's financial performance. The governance examined is related to the number of board of directors and commissioners' meetings as well as director education, as well as intellectual capital with the variables Human Capital Efficiency (HCE), Capital Efficiency Structure (SCE), and Capital Employed Efficiency (CEE). The financial performance of Return On Assets (ROA) becomes an intervening variable on the variable Asset Growth (AG) of Islamic commercial bank companies.

Some previous studies that underlie the existence of this study include research by Tri Ciptaningsih (2013). The research aims to examine the effect of intellectual capital on the company's financial performance, where the variables analyzed are Intellectual Capital, VAIC, HR capital, structural capital and financial performance. The results of the study are that VAIC and HCE have no effect on the company's financial performance and CEE and SCE have a positive effect on the company's financial performance. (Ciptaningsih, 2013).

Previous research has been conducted on the relationship between the application of governance and corporate financial performance. Among them is Santoso's research (2017) which shows that the application of good corporate governance has a significant positive direct effect on company value. While in the same research it shows that Good Corporate Governance has a significant indirect effect on firm value by using financial performance (ROA) as an intervening variable. This research was conducted by taking samples of manufacturing companies in the logan, chemical and plastic packaging sectors listed on the Indonesia Stock Exchange (IDX) during 2011 to 2016 or as many as 54 companies.

Meanwhile, according to research conducted by Farida, et.al (2010), the results show that the application of corporate governance to earnings management in Indonesian banking companies has a significant effect only on the proxy for managerial ownership. Another result is the absence of a relationship between the application of corporate governance to financial performance mediated by management earnings actions in Indonesian banking companies. Taking the corporate governance variable is represented by the size of the board of commissioners, the composition of the independent board of commissioners, the audit committee, institutional ownership, and managerial ownership. This study takes a sample is an Indonesian banking company that listed on the Stock Exchange within the period from 2005 to 2007.

Research by Suroso, et.al (2017) states that there is a significant and significant influence of intellectual capital on the RPA and no effect on AG. Still, from the same study, Suroso, et. al (2017) states that for corporate governance has a positive influence on ROA and does not affect the growth of assets.

### **Intellectual Capital (IC)**

Intellectual Capital is one of the intangible corporate assets. This intellectual capital is the development of the needs of a company that initially only relies on physical assets (tangible assets) which then develops with the need for intangible assets (intangible assets). Intellectual Capital is an intangible asset, which has no physical form, but has a value that can generate profits and can be a competitive advantage for organizations (Choong, 2008). This development makes intellectual capital as one of the capital in carrying out company operations as well as physical capital as before. The importance of the role and contribution of intangible assets can be seen in the comparison between book value and market value in knowledge-based companies. (S.W et, al. 2012).

Calculation of the efficiency and effectiveness of an intellectual capital against company profits, where intellectual capital provides added value to the company can be known by using the VAIC method. This method aims to create as much added value as possible with a number of physical capital and intellectual potential. (Pulic, 1998).

The calculation of the VAIC is  $VAIC = ICE + CEE$  (Pulic, 2008) with the ICE are intellectual capital efficiency coefficient (HSE+SCE) and the CEE is the capital employed efficiency coefficient.

The main components of VAIC that can be seen from company resources, are human capital (VAHU - value added human capital), Structural Capital (STVA - structural capital value added), and physical capital (VACA - value added capital employed). (Kartika, et.al, 2013).

Part of intellectual capital is what is examined in this research is :

- 1) HCE  
Human Capital Efficiency is capital related to the development of a company's human resources, such as competence, commitment, motivation, and employee loyalty. Human Capital shows the company's ability to manage human resources. (Salim et al., 2013).
- 2) Structure Capital Efficiency (SCE)  
Structure Capital Efficiency shows the existing knowledge in a company that is human, such as: company routines, procedures, systems, culture and databases (Salim et. Al, 2013).  
Structure Capital Efficiency is a development that has been carried out within the company and has become the culture of the company, so that it can be a strength in the future development of the company.
- 3) Capital Employed Efficiency (CEE)  
Capital Employed shows a harmonious relationship with its partners, such as suppliers, customers, government, and surrounding communities (Salim et. Al, 2013). Capital Employed Efficiency is the amount of capital in the form of financial funds that have been invested into the company in order to carry out the company's operational activities that can create added value for the company.

### **Corporate Governance**

Corporate governance is a system that is run and carried out by a company in managing, controlling, and daily activities. Good corporate governance is able to facilitate the interests and needs of all stakeholders or corporate stakeholders involved in the process and management of the company.

Corporate governance begins with the concept of separation between ownership and control. This separation led to agency theory, where between the two have different interests. Organizational theory and company policy are strongly influenced by agency theory that describes top managers as agents in a company, where these managers have different interests from the owner, still trying to maximize their respective satisfaction. (Jensen & Meckling (1976) in Raharjo, 2007)

The application of corporate governance has a relationship with company profits. Through a mechanism of good corporate governance, it is expected to be operated by higher earnings (Khafid, 2012).

### Return On Asset

Return on Assets (ROA) according to Tandelilin (2010), is to illustrate the extent to which the ability of assets owned by a company can generate profits. ROA is measured by comparing net income with total assets. Edwin, et. al (2017). Meanwhile according to Kasmir (2010), Return On Assets is a ratio that shows the results of the total assets used in the company

Return on Assets Ratio (ROA) is the rate of return or profit of a company that is obtained compared with the assets owned by the company. Company performance is the result of implementing company policies such as ROA that will be used by investors and prospective investors as a basic for their decision to invest. (Salim, et. al, 2019)

Companies with high return on assets (ROA) will attract investors to invest their capital to the company because the company is considered to be more efficient in generating profits by utilizing all assets owned by the company. (Mulyana, et.al, 2017).

### Asset Growth

Asset growth is growth in the value of assets owned by a company compared to the value of assets in the previous period. The company certainly hopes that the company's assets can increase along with the company's progress.

Asset growth can use a debt scheme or from company wealth. If the company uses debt, then the manager will be forced to issue cash from the company to pay interest. (Umaiyah, et. al. 2017).

## 2. Material and Methods

The framework of thought used in this study can be described as follows

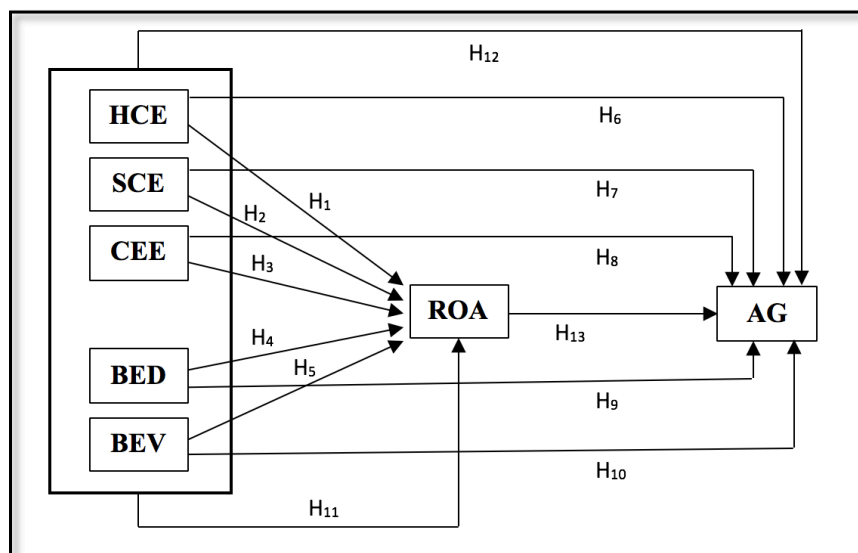

Figure 1. The framework

Based on that framework, the hypothesis of this research is as follows : H1: HCE affects ROA. H2 : SCE affects ROA. H3 : CEE affects ROA. H4 : BED affects ROA. H5 : BEV affects ROA. H6: HCE affects AG. H7 : SCE affects AG. H8 : CEE affects AG. H9 : BED affects AG. H10 : BEV affects AG. H11 : HCE, SCE, CEE, BED,

BEV affects simultaneously on ROA. H12 : HCE, SCE, CEE, BED, BEV affects simultaneously on ROA. H13 : ROA affects AG.

Table 1 : Operational Definitions and variable measurements

No.	Variable	Indicator	Data Source
1.	Human Capital Efficiency (HCE)	$HCE = \frac{Value\ Added\ (VA_i)}{Human\ Capital\ (HC_i)}$	Annual Report
2.	Structure Capital Efficiency (SCE)	$SCE = \frac{Structural\ Capital\ (SC_i)}{Value\ Added\ (VA_i)}$	Annual Report
3.	Capital Employed Efficiency (CEE)	$CEE = \frac{Value\ Added\ (VA_i)}{Capital\ Employed\ (CE_i)}$	Annual Report
4.	Board of Education (BED)	$BED = \frac{education\ level\ of\ directors}{maximum\ level\ of\ education}$	Annual Report
5.	Board of Evaluation (BEV)	$BEV = \frac{total\ attendance\ meeting}{total\ meeting\ x\ directors}$	Annual Report
6.	Return On Asset (ROA)	$ROA = \frac{Net\ Income\ after\ Tax}{Total\ Aset}$	Annual Report
7.	Asset Growth (AG)	$AG = \frac{asset\ addition_n}{Asset\ at\ year_{n-1}} \times 100\%$	Annual Report

Population is a generalization area that consists of objects / subjects that have certain qualities and characteristics that are determined by researchers to be studied and then drawn conclusions (Sugiyono, 2011). The population in this study are all Sharia commercial banks in Indonesia. From this population, criteria were determined in determining the samples to be used in this study. The criteria for determining the sample are as follows:

Table 2 : Sampling criteria

No.	Criteria	Amount
1	All sharia commercial banks, and not including sharia units or Sharia Regional Development Banks.	14
2	All sharia commercial banks in Indonesia, both private and state-owned.	12
3	All sharia commercial banks that have started operating since 2014 to 2018 adjusted to the observation period.	12
	Number of companies that meet the criteria	12

The data used are panel data derived from annual reports from the companies included in the sample with sample duration. The panel data regression model used in this study is to combine cross section data with time series data. Data cross section is the parameters observed and analyzed by the company, while the time series data is the period of observation in the study, which is for a period of 5 years. Thus, the more population taken, and also the wider the time span used as observation, the more panel data obtained.

Panel data regression is a regression that uses observations of one or more variables in a unit continuously for several periods of time (Ratnasari, et. Al, 2014). The general models that will be used in this study are as follows (Dencik; Fitriya, Mohammad, Noor. 2018)

$$Y_{ij} = \mu + \alpha_j + \varepsilon_{ij} \dots\dots\dots(1)$$

With:

- $Y_{ij}$  is the subject of the dependent variable for experiment
- $\mu$  is a constant that represents a value that does not depend on the dependent variable for various experimental conditions.
- $\alpha_j$  is the effect of various experimental conditions and random variables
- $\varepsilon_{ij}$  is an error term.

From that general equation, this study would use the regression equations as follow:

$$\text{Equation 1 : } ROA = \alpha_{it} + \beta_{1it} \cdot BED_{it} + \beta_{2it} \cdot BEV_{it} + \beta_{3it} \cdot HCE_{it} + \beta_{4it} \cdot SCE_{it} + \beta_{5it} \cdot CEE_{it} \dots\dots (2)$$

$$\text{Equation 2 : } AG = \alpha_{it} + \beta_{1it} \cdot BED_{it} + \beta_{2it} \cdot BEV_{it} + \beta_{3it} \cdot HCE_{it} + \beta_{4it} \cdot SCE_{it} + \beta_{5it} \cdot CEE_{it} \dots\dots (3)$$

$$\text{Equation 3 : } AG = \alpha_{it} + \beta_{1t} \cdot ROA_{it} \dots\dots\dots(4)$$

The data was processed using eviews version 8 software, and description analysis will be carried out first before we did the panel data regression analysis. Determination of the estimation model is done by conducting a chow test, a hausman test and a Lagrange Multiplier test. (Astuti, 2017). Meanwhile, the Lagrange Multiplier test will only be done if the results of the chow test and the Hausman test show different results.

There are 4 classic assumption tests that can be applied in this study. The purpose of this classic assumption test is to provide certainty that the regression equation obtained has accuracy in estimation, is unbiased and consistent. The tests included in the classic assumption test are the normality test, the autocorrelation test, the heterokedasticity test, and the multicollinity test.

In connection with the use of panel data in this study, the classic assumption test was not conducted. According to Gujarati 2012 in Kasmiarno. et. al (2017) classic assumption test is not needed in panel data analysis because panel data can minimize the bias that is most likely to appear in the results of the analysis, giving more information, variations, and degrees of freedom.

Determination of the estimation model is done to determine the best estimation model among the three models, namely the Fixed Effect Model, Common Effect Model, or Random Effect Model. In panel data regression a regression estimation model is used, i.e Common Effect Model (CEM), Fixed Effect Model (FEM) dan Random Effect Model (REM) (Astuti, 2017). And for the last, regression model is done by using the T-test, F-test, and the determination Coefficient R square. The test would use the value is 0.05 or 5%.

### 3. Result and Discussion

The companies included in the sample in this study were 12 Sharia commercial banks. For the descriptive analysis, the study found :

Table 3 : descriptive analysis

	HCE	SCE	CEE	BED	BEV	ROA	AG
Mean	89.62917	52.01950	17.45150	72.98617	85.92633	-0.293667	29.74133
Median	137.8250	31.86500	20.82000	73.33000	90.65000	0.300000	14.10000
Maximum	369.5000	657.3200	89.08000	85.00000	100.0000	8.020000	1134.870
Minimum	-1181.540	-275.5900	-299.2400	60.00000	14.29000	-16.89000	-48.11000
Std. Dev.	219.8696	110.2893	48.53178	5.393975	14.70048	3.904465	146.2563
Skewness	-3.980396	2.757522	-4.660578	-0.238598	-2.499611	-2.094189	7.364548

Kurtosis	21.53675	18.48374	31.59759	3.661008	11.21073	9.547458	56.19099
Jarque-Bera Probability	1017.464	675.4046	2261.766	1.661616	231.0209	151.0293	7615.569
Sum	5377.750	3121.170	1047.090	4379.170	5155.580	-17.62000	1784.480
Sum Sq. Dev.	2852217.	717659.7	138964.7	1716.603	12750.14	899.4458	1262063.
Observations	60	60	60	60	60	60	60

### T-Test

T-Test conducted to determine the partially significant effect of each independent variable whether it affects the dependent variable. Hypothesis for this T-Test are : Ho : is no effect of independent variables on dependent variable. Ha : there is influence of the independent variables on dependent variable.

Decision criteria is: if the probability value of the independent variable is smaller than 0.05 then there is the influence of the independent variable on the dependent variable. If the probability value of the independent variable is greater than 0.05 then there is no effect of the independent variable on the dependent variable.

Table 4 : T-Test

No.	Variable		T Test
Equation 1			
$ROA = \alpha_{it} + \beta_{1it}.BED_{it} + \beta_{2it}.BEV_{it} + \beta_{3it}.HCE_{it} + \beta_{4it}.SCE_{it} + \beta_{5it}.CEE_{it}$			
1.	HCE	0.0000	Ho is rejected. HCE has a significant effect on ROA
2.	SCE	0.3203	Ho accepted. SCE does not have a significant effect on ROA
3.	CEE	0.2206	Ho accepted. CEE does not have a significant effect on ROA
4.	BED	0.7656	Ho accepted. BED does not have a significant effect on ROA
5.	BEV	0.2728	Ho accepted. BEV does not have a significant effect on ROA
Equation 2			
$AG = \alpha_{it} + \beta_{1it}.BED_{it} + \beta_{2it}.BEV_{it} + \beta_{3it}.HCE_{it} + \beta_{4it}.SCE_{it} + \beta_{5it}.CEE_{it}$			
1.	HCE	0.0116	Ho is rejected. HCE have a significant effect on AG
2.	SCE	0.4704	Ho accepted. SCE does not have a significant effect on AG
3.	CEE	0.9889	Ho accepted. CEE does not have a significant effect on AG
4.	BED	0.3500	Ho accepted. BED does not have a significant effect on AG
5.	BEV	0.8757	Ho accepted. BEV does not have a significant effect on AG
Equation 3			
$AG = \alpha_{it} + \beta_{1it}.ROA_{it}$			
1.	ROA	0.0000	Ho is rejected. ROA has a significant effect on AG

### F-Test

This test is a test to find out the significance level of all independent variables simultaneously on the dependent variable. Hypothesis for this test are : Ho : is no effect of independent variables on dependent variable. Ha : there is influence of the independent variables on dependent variable. For each equation, independent variables are BED, BEV, HCE, SCE, CEE. For equation 1, dependent variable is ROA. For equation 2, dependent variable is AG. Decision criteria is: if the probability value of the F statistic is smaller than 0.05 then there is the influence of the independent variable on the dependent variable. If the probability value of the F statistic is greater than 0.05 then there is no effect of the independent variable on the dependent variable.

Table 5 : F-Test

No.	Equation	F Test
1.	$ROA = \alpha_{it} + \beta_{1it}.BED_{it} + \beta_{2it}.BEV_{it} + \beta_{3it}.HCE_{it} + \beta_{4it}.SCE_{it} + \beta_{5it}.CEE_{it}$	0.000000 Ho is rejected. BED, BEV, HCE, SCE, CEE simultaneously influence ROA
2.	$AG = \alpha_{it} + \beta_{1it}.BED_{it} + \beta_{2it}.BEV_{it} + \beta_{3it}.HCE_{it} + \beta_{4it}.SCE_{it} + \beta_{5it}.CEE_{it}$	0.020743 Ho is rejected. BED, BEV, HCE, SCE, CEE simultaneously influence AG

**Determination coefficient R<sup>2</sup>**

This test is used to find out how much the proportion of dependent variation can be influenced by the independent variable. This test measures how far the independent variable explains the variation of the dependent variable.

The result of this test are :

Table 6 : Determination coefficient R<sup>2</sup>

No.	Equation	Coefficient of Determination	
1.	$ROA = \alpha_{it} + \beta_{1it}.BED_{it} + \beta_{2it}.BEV_{it} + \beta_{3it}.HCE_{it} + \beta_{4it}.SCE_{it} + \beta_{5it}.CEE_{it}$	R <sup>1</sup> <sup>2</sup>	0.9366661
2.	$AG = \alpha_{it} + \beta_{1it}.BED_{it} + \beta_{2it}.BEV_{it} + \beta_{3it}.HCE_{it} + \beta_{4it}.SCE_{it} + \beta_{5it}.CEE_{it}$	R <sup>2</sup> <sup>2</sup>	0.213211
3.	$AG = \alpha_{it} + \beta_{1it}.ROA_{it}$	R <sup>3</sup> <sup>2</sup>	0.346701
		$R_1^2 + R_3^2 > R_2^2$ 0.9366661 + 0.346701 > 0.213211	

The final equation for each are :

## 1) Equation 1 :

From Equation 1, the study found that the best model that we can do is the Fixed Effect Model (FEM). The final equation 1, based on the result of the study is  $ROA = 1.026998 + 0.011812 HCE - 0.001600 SCE + 0.006697 CEE - 0.014393 BED - 0.015857 BEV$ .

From them, study analysis the effect from the independent variable to the ROA, found that only HCE is have the significant partial effect to the ROA. Besides that, for the simultaneous effect, study found that all independent variable have significant effect to the ROA. The contribution of all independent variables to ROA was 93.66661%. The rest comes from other variables not examined in this study.

## 2) Equation 2 :

From Equation 2, the study found that the best model that we can do is the Common Effect Model (CEM). The final equation 2, based on the result of the study is  $AG = 37.29616 + 0.035754 HCE - 0.0155505 SCE - 0.000896 CEE - 0.421894 BED + 0.024787 BEV$

From them, study analysis the effect from the independent variable to the AG, found that only HCE is have the significant partial effect to the AG. Besides that, for the simultaneous effect, study found that all independent variable have significant effect to the AG. The contribution of all independent variables to AG was 21.3211%. The rest comes from other variables not examined in this study.

## 3) Equation 3 :

From Equation 3, the study found that the best model that we can do is the Common Effect Model (CEM). The final equation 3, based on the result of the study is  $AG = 11.83246 + 2.780300 ROA$ .

From them, study analysis the effect from the ROA to the AG, found that ROA have the significant effect to the AG. ROA's contribution to AG was 34.6701%. The rest comes from other variables not examined in this study.

## Discussions

- 1) HCE has a statistically significant effect on ROA. This is indicated by the probability value of HCE against ROA is 0.0000 where the value is less than 0.05.  
This shows that the quality of human resources, and all costs incurred in relation to human resources have a significant impact on increasing ROA.  
From the final formula obtained for this equation 1, it is found that each increase of 1 unit of HCE will cause an increase in ROA of 0.011812 units. This means that the increase in costs given to employees in order to increase the ability of employees will be able to increase the achievement of company ROA. The ability of employees to do all their activities determines the company's operational activities that ultimately can increase the achievement of ROA.  
These results are in line with the results of research from Dwipayani. et. al (2014) which states that Human Capital Efficiency does not have a significant negative effect on Return on Assets (ROA). This result is not in line with the results of research from Ciptaningsih (2013) which states that the efficiency of Human Resources owned by the company apparently does not have a significant influence on the company's current financial performance. Another study by Aritonang (2016) found that the HCE component did not have a positive and significant influence on the company's financial performance in the next 1 year.
- 2) SCE has a statistically negative and not significant effect on ROA. This is indicated by the probability value of SCE to ROA is 0.3203. This number is greater than 0.05 so it can be interpreted that the SCE variable has no significant effect on ROA and AG.  
From the final formula obtained for this equation 1, it is found that each increase of 1 unit of SCE will cause a decrease in ROA of 0.001600 units. This means that is all the efforts of the company in improving corporate culture, the company system will have the effect of reducing corporate profits. Improving the company's culture cannot necessarily increase profits and the company's ROA ratio at the same time. Corporate culture can improve employee work efficiency but not in a short time.  
This result is in line with the results from Ciptaningsih (2013) study which states that even though the company has good efficiency of its structural capital does not necessarily indicate the prospect of improved financial performance in the future.  
But these results are not in line with the results of research from Dwipayani. et. al (2014) which states that Intellectual Capital, Structural Capital Efficiency, and Capital Employed Efficiency have a significant positive effect on Return on Assets (ROA).  
Other studies also with results that are not in line, namely by Aritonang (2016) with the results that the SCE component is positive and significant effect on the company's financial performance.
- 3) CEE has a statistically positive and not significant effect on ROA. This is indicated by the probability value of CEE to the profitability of the company represented by the variable ROA is 0.2206. This number is greater than 0.05 so it can be interpreted that the CEE variable has no significant effect on ROA.  
From the final formula obtained for this equation 1, it is found that each increase of 1 unit of CEE will cause an increase in ROA of 0.006697 units. This means that the greater the company's relationships and relationships with other partners, the greater the revenue that will be obtained by the company, and ultimately can increase the company's ROA. The company is able to get more accurate information from partners related to the company's efforts to obtain greater profits.  
This research is not in line with the results of research by Ciptaningsih (2013), which states that the results of the analysis note that what has proven to consistently affect the company's financial performance is the CEE (Capital Employed Efficiency) variable. Other studies are also not in line with the results of Dwipayani. et. al (2014) which states that Intellectual Capital, Structural Capital Efficiency, and Capital Employed Efficiency have a significant positive effect on Return on Assets (ROA). Another research that is not in line is the research by Aritonang (2016) which states that the CEE component has a positive and significant effect on the company's financial performance in the future.

- 4) BED has a statistically negative and not significant effect on ROA. This is indicated by the probability value of the BED against ROA is 0.7656. This number is greater than 0.05 so it can be interpreted that the CEE variable has no significant effect on ROA.  
From the final formula obtained for this equation 1, it is found that each increase of 1 unit of BED will cause a decrease in ROA of 0.014393 units. This means that the greater the age of directors, the directors are less brave in making decisions to increase company revenue. Decisions taken by directors are only normative and there are not many breakthroughs that dare to be taken by directors in terms of increasing company revenue. These results are not in line with the results of research by Erlim. et. al (2017) which states that CEO education level has a positive effect on company performance as measured by Tobin's Q. Tobin's Q is an evaluation of the company's value and its effect on the market or market.
- 5) BEV has a statistically negative and not significant effect on ROA. This is indicated by the probability value of BEV against ROA is 0.2728. This figure is greater than 0.05 so it can be interpreted that the BEV variable has no significant effect on ROA. This insignificant effect is that the number of directors' attendance at board of directors meetings does not significantly affect the achievement of company ROA.  
From the final formula obtained for this equation 1, it was found that each increase of 1 unit of BEV will cause a decrease in ROA of 0.015857 units. This means that the more directors' meetings are held, the higher the attendance of the directors can cause a decrease in company ROA. Decisions that should be taken by directors in terms of routine operational problems are constrained because of the routine in the directors meeting that must be made.
- 6) HCE statistically has a positive and significant effect on AG. This is indicated by the probability value of HCE against AG is 0.0116 where the value is less than 0.05.  
From the final formula obtained for equation 2, it is found that each increase of 1 unit of HCE will cause an increase in AG of 0.035754 units. This positive influence shows that the higher the company in spending costs to improve the ability of its employees in carrying out operational processes in the company will have a positive impact on increasing company assets.  
However, these results are not in line with the results of research from Ciptaningsih (2013) which states that the efficiency of Human Resources owned by the company apparently did not have a significant effect on the company's current financial performance.  
This shows that the quality of human resources, and all costs incurred in relation to human resources have a significant impact on increasing AG.
- 7) SCE has a statistically negative and not significant effect on AG. This is indicated by the probability value of SCE against AG is 0.4704. This number is greater than 0.05 so it can be interpreted that the SCE variable has no significant effect on AG.  
From the final formula obtained for equation 2, it is found that each increase of 1 unit of SCE will cause a decrease in AG of 0.0155505 units. This negative influence shows that the higher the company develops corporate culture in order to develop optimal company performance, the lower the increase in assets by the company. This can be interpreted that the company is still in the stage of developing a corporate culture and requires capital to improve the quality of human resources through various efforts. The development of a company's performance can not directly provide immediate and rapid results to increase company assets.  
This result is in line with the results of a study by Ciptaningsih (2013) which states that even though a company has good efficiency of its structural capital does not necessarily indicate the prospect of improved financial performance in the future.
- 8) CEE has a statistically negative and not significant effect on AG. This is indicated by the probability value of CEE on the AG variable is 0.9889. Both of these numbers are greater than 0.05 so it can be interpreted that the CEE variable has no significant effect on AG.  
From the final formula obtained for equation 2, it is found that each increase of 1 unit of CEE will cause a decrease in AG of 0,000896 units. This negative influence shows that the higher the relationship and the company's relationship with related partners, the lower the increase in company assets. Companies will be more encouraged to increase the availability of operational materials compared to the company's needs to

develop assets.

These results are not in line with the results of the research by Ciptaningsih (2013), which states that the results of the analysis note that what is proven to consistently affect the company's financial performance is the variable CEE (Capital Employed Efficiency).

- 9) BED has a statistically negative and not significant effect on AG. This is indicated by the probability value of the BED against AG is 0.3500. This number is greater than 0.05 so it can be interpreted that the CEE variable has no significant effect on AG.  
From the final formula obtained for this equation 2, it is found that each increase of 1 unit of BED will cause a decrease in AG of 0.421894 units. This negative influence shows that the higher the age of the board of directors, the more reluctant to develop their assets. The orientation of the board of directors towards the direction of the company is to increase profits so that it increases so that it increases the value of the company. These results are not in line with the results of research by Erlim. et. al (2017) which states that CEO education level has a positive effect on company performance as measured by Tobin's Q. Tobin's Q is an evaluation of the company's value and its effect on the market or market.
- 10) BEV has a statistically positive and not significant effect on AG. This is indicated by the probability value of BEV against AG is 0.8757. This number is greater than 0.05 so it can be interpreted that the BEV variable has no significant effect on AG.  
From the final formula obtained for this equation 2, it is found that each increase of 1 unit of BEV will cause an increase in AG of 0.024787 units. This effect is not significant because the increase in AG obtained is not proportional to the effort to get a 1 unit increase in BEV.
- 11) Statistically, independent variables (HCE, SCE, CEE, BED, BEV) have a significant effect on ROA. This is indicated by the probability value of 0.000000 which is less than 0.05 so that all independent variables have a significant simultaneous effect on ROA.  
The influence of all independent variables on the ROA variable based on the coefficient of determination obtained a value of 93.6661%. The rest, is the influence of other variables outside the independent variables examined in this study. Efforts to improve all independent variables in this study can significantly improve the achievement of company ROA.  
This result is in line with the results of research by Erlim. et. al (2017) which states that the Intellectual Capital variable measured by VAIC obtained has a significant positive effect on profitability of ROA.
- 12) Statistically, independent variables (HCE, SCE, CEE, BED, BEV) have a significant effect on AG. This is indicated by the probability value of 0.020743 which is less than 0.05 so that all independent variables have a significant simultaneous effect on AG.  
The influence of all independent variables on the AG variable based on the coefficient of determination obtained a value of 21.3211%. The rest, is the influence of other variables outside the independent variables examined in this study. Although it has a significant effect, all independent variables only have an effect of 21.3211% on the increase in assets. This means that the increase in assets is also much influenced by other factors such as policy and direction of the company that is not examined in this study.
- 13) ROA has a statistically significant effect on AG. This is indicated by the probability value of ROA against AG that is 0.0000. This number is smaller than 0.05 so it can be interpreted that the ROA variable has a significant effect on AG.  
From the final formula obtained, namely  $AG = 11.83246 + 2.780300 ROA$ , it can be interpreted that an increase in ROA by 1 unit can increase AG by 2.780300 units.  
Increase in Asset or Asset Growth is very much influenced by the company's return on assets or ROA. The return of assets obtained from the net profit of an Islamic bank company will make that asset growth also accelerate.  
ROA is a ratio of return on assets owned by a company from the amount of profit achieved. Companies that have high ROA values can have opportunities to develop their assets, and vice versa if the value of ROA is small then the possibility for asset development is also getting smaller and the company will focus more on

the company's operations.

#### 4. Conclusion and Suggestions

The conclusions of this study are as follows:

- 1) There is partial positive significant influence from Human Capital Efficiency to Return On Asset
- 2) There is partial negative and not significant influence from Structural Capital Efficiency to Return On Asset
- 3) There is partial positive and not significant influence from Capital Employed Efficiency to Return On Asset
- 4) There is partial negative and not significant influence from Board of Education to Return On Asset
- 5) There is partial negative and not significant influence from Board of Evaluation to Return On Asset
- 6) There is partial positive and significant influence from Human Capital Efficiency to Asset Growth
- 7) There is partial negative and not significant influence from Structural Capital Efficiency to Asset Growth
- 8) There is partial negative and not significant influence from Capital Employed Efficiency to Asset Growth
- 9) There is partial negative and not significant influence from Board of Education to Asset Growth
- 10) There is partial positive and not significant influence from Board of Evaluation to Asset Growth
- 11) There are simultaneous significant influence from independent variables to Return on Asset.
- 12) There are simultaneous significant influence from independent variables to Asset Growth.
- 13) There is positive and significant influence from Return on Asset to Asset Growth

The Suggestions from this study are :

- 1) For further research, it should be able to see other aspects of corporate governance (such as the number of committee members under the commissioners, the number of commissioners, the education of the commissioners) and their influence on ROA and AG in Islamic commercial bank companies.
- 2) For the further research, it should add a dummy variable for islamic commercial banks which are subsidiaries of commercial banks. Are the commercial banks as the holding company give effect to the policy of the islamic banks.

#### References

- Aritonang, Qaharuna Agasa Setyadam. Muharam, Harjum. Sugiono. (2016). Effect of Intellectual Capital on Financial Performance. *business strategy journal*. 25(1) pp 1 - 17.
- Astuti, Wahyu Indri. Ratnasari, Vita. Wibowo, Wahyu. (2017). Analysis of Factors affecting the Open Unemployment rate in East Java Province Using Panel Data Regression. *Saint Journal and Art*. 6(1). pp 150-156.
- Choong, Kwee Keong. (2008). Intellectual Capital : Definitions, Categorization and reporting models. *Journal of Intellectual Capital*. 9(4). pp 609 - 638. DOI : <https://doi.org/10.1108/14691930810913186>
- Ciptaningsih, Tri. (2013). Test of the Effect of Intellectual Capital on the Financial Performance of SOEs Going Public in Indonesia. *Journal of Technology Management*. 12(3). dec. 2013.
- Dencik, Abdul Basyith. Yahya, Fitriya Fauzi. Yoesoef, Mohammad Idris. Salim, M. Noor (2018). *Multivariate Statistics Analysis of Anova, Manova, Ancova, Repeated Measured with Excel and SPSS Applications*. First Edition, Oktober 2018. Publishers: Rajawali Pers. Depok. West Java. Indonesia.
- Dwipayani, Chrisnatty Chandra. Prastiwi, Andri. (2014). The Effect of Intellectual Capital on Profitability and Market Performance. *Diponegoro Journal of Accounting*. 3(3). 2014. Pp.201-209.
- Erlim, Kevin Wiyarta. Juliana, Rita. (2017). Effects of Education Level and CEO Education Specialization on Company Performance in Indonesia. *Maranatha Management Journal*. 16(2). Pp 133 – 212.
- Umaiyah, Erwin. Salim, M. Noor. (2017). Financial Ratios, Company Size, Capital Structure and Its Impacts on the Value of Non-Banking Companies in the LQ-45 Category. *Indicator Journal*. 2(3). Pp 120 – 135.
- S.W., Indah Fajarini. Firmansyah, Riza. (2012). The Effect of Intellectual Capital on Company Financial Performance (Empirical Study of LQ-45 Companies). *Journal of accounting dynamics*. 4(1). pp 1-12
- Farida, Yustiati Nur. Prasetyo, Yuli. Heriyanti. Eliada. (2010). The Influence of the Implementation of Corporate Governance on the Income of Earning Management in Assessing Financial Performance in Banking Companies in Indonesia. *Business and Accounting journals*. 12(2). pp 69-81.
- Kartika, Martha. Hatane, Saarce Alsye. (2013). The Effect of Intellectual Capital on the Profitability of Banking Companies Listed on the Indonesia Stock Exchange in 2007-2011. *Business Accounting Review*, 1(2). pp. 14-22.

- Kasmiarno, Kurnia Sari. Mintaroem, Karjadi. (2017). Analysis of the Effect of Economic Indicators and Sharia Banking Performance on Manpower Absorption in Sharia Banking in Indonesia 2008 – 2014. *Journal of Sharia Theory and Applied Economics*. 4(1). pp. 14-26.
- Kasmir, S.E (2010). *Introduction to Financial Management*. Second edition. Kencana. Jakarta.
- Khafid, Muhammad. (2012). Effect of Corporate Governance and Ownership Structure on Profit Persistence. *Journal of accounting dynamics*. 4(2). pp. 139-148.
- Kurniasih, Augustina. Helianton. (2016). Intellectual Capital of a BUMN Open Bank and Its Impact on Company Performance. *MIX Scientific Management Journal*. 6(2). pp. 195-212.
- Mulyana, Bambang. Rini, Rahmatika. (2017). The Effect of Solvency, Profitability, Company Size and Stock Beta on the Value of the Company and Its Impact on the Returns of Companies in the Automotive Sub Sector and its Components listed on the Indonesia Stock Exchange for the Period of 2020-2016. *Journal indicator*. 1(3). pp. 17-30.
- Nuswandari, Cahyani. (2009). The Effect of Corporate Governance Perception Index on Company Performance on Companies Listed on the Jakarta Stock Exchange. *Journal of business and economics (JBE)*. 16(2). pp 70-84.
- Pulic, Ante. (1998). *“Measuring the Performance of Intellectual Potential in Knowledge Economy”*.  
\_\_\_\_\_. (2008). *“The Principles of Intellectual Capital Efficiency - A Brief Description*. Croatian Intellectual Capital Center, Zagreb. 76.
- Raharjo, Eko. (2007). Agency Theory and Stewardship Theory in Accounting Perspectives”. *economic focus*. 2(1). pp. 37-46.
- Ratnasari, Ni Putu Anik Mas. Kencana, I Putu Eka Nila. Gandhiadi, G. K. (2014). Application of Panel Data Regression with Fixed Effect Model Approach. *Mathematics e-journal*. 3(1). pp 1-7.
- Salim, Selvi Meliza. Karyawati, Golrida. (2013). *“Effect of Intellectual Capital on financial performance”*. *Journal of Business and Entrepreneurship* 1(2). Pp. 74 – 91.
- Salim, M. Noor. Wahyuni, Evilin Sri. 2019. The Effect of Internal, External Factors On Corporate Performance and Its Impact On Corporate Values in Indonesia Manufacturing Companies in The Automotive Sub Sector and Its Components in 2008-2017. *International Journal of Engineering Technologies and Management Research*. Volume 6 (Iss. 6). pp 101-115. DOI: 10.5281/zenodo.3266140
- Santoso, Agus. (2017). Effect of Good Corporate Governance on firm value with financial performance as an intervening variable. *Proceedings Seminar Nasional and Call For Paper Economic and Business*. Jember, Oct 27-28 2017. Pp. 67 - 77.
- Suroso, Sugeng. Widyastuti, Tri. Salim, M. Noor. Setyawati, Irma (2017). Intellectual Capital and Corporate Governance in Financial Performance Indonesia Islamic Banking. *International Journal of Economics and Financial Issues*. 2017. 7(4). pp 96-103.
- Sugiyono, Prof. (2011). *“Quantitative, Qualitative, and R&D Research Methods”*. Bandung. Alfabeta, Bandung.
- Syafrida, Ida. Abror. Ahmad. (2011). Factors That Influence Sharia Banking Asset Growth in Indonesia. *Journal of economics and business*. 10(1). pp 19-24.
- Tandelilin, Eduardus. (2010). *Portfolio and Investment Theories and Applications*. Kanisius. Yogyakarta.
- Tertius, Melia Agustina. Christiawan, Yulius Jogi. (2015). The Effect of Good Corporate Governance on Company performance in the Financial Sector. *Business Accounting Review*. 3(1). pp. 223-232.
- Zubair, Muhammad Kamal. (2008). Growth Acceleration of Islamic Banks in Indonesia. *Millah*. 2008. 8(1). pp 1-16. DOI: <https://doi.org/10.20885/millah.vol8.iss1.art1>